



K46/T40/TLT200 TRANSAXLE AXLE SEAL REPLACEMENT PROCEDURE

Presented by TTC

Time required: 10 minutes

Note: Some models may vary in appearance or fan/pulley stack-up. This diagram is intended to provide information for the replacement of the Axle Seal only. Proper safety equipment is recommended.

Tools Needed

- ⚙️ Electrical Tape
- ⚙️ Grease
- ⚙️ Rubber mallet / hammer
- ⚙️ 21 mm box end wrench
- ⚙️ Flat screw driver



Work Area: All work must be performed in a clean and well-lit area to prevent contaminations from entering the hydro mechanical drive system.

 Use a flat head screw driver to extract the leaking axle seal from the transaxle case.

 Clean the seal mating surface with a clean towel.

 Wrap tape around the axle starting inboard and ending at the tip of shaft in order to cover keyway and protect double lips of new seal during installation.



 Apply a generous coating of grease between the double lips of new seal and over the newly applied tape on axle.





 Slide seal onto wrapped axle shaft. Seal side with lip retainer spring should be on inboard side.

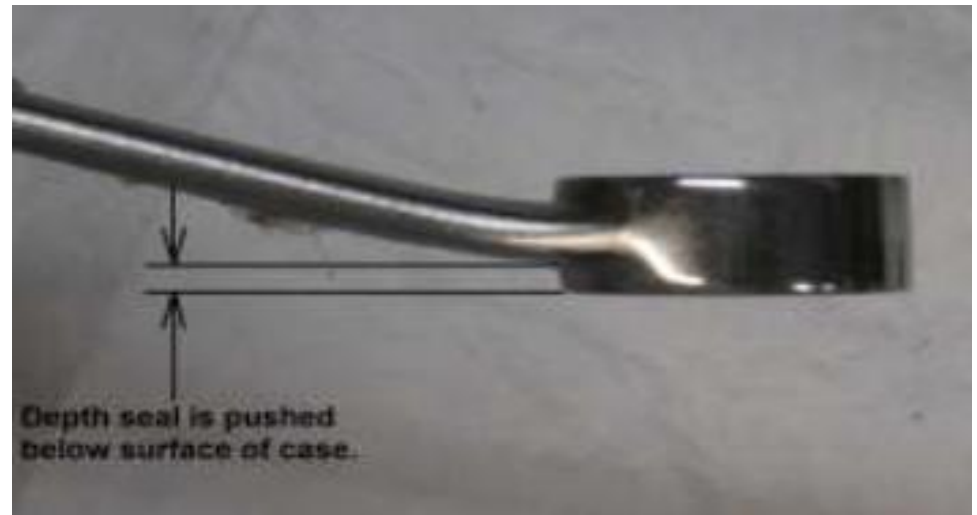

 Tap against end of wrench to drive seal about 1/8" below surface of housing, to the depth where chamfer on case port ends. Note: Be careful not to damage the upper housing.



 Once it is properly driven in about 1/8" below surface of housing, to the depth where chamfer on case port ends.

 Wipe the seal area with a clean towel and inspect for leaks.

 Remove the tape from the axle shaft.

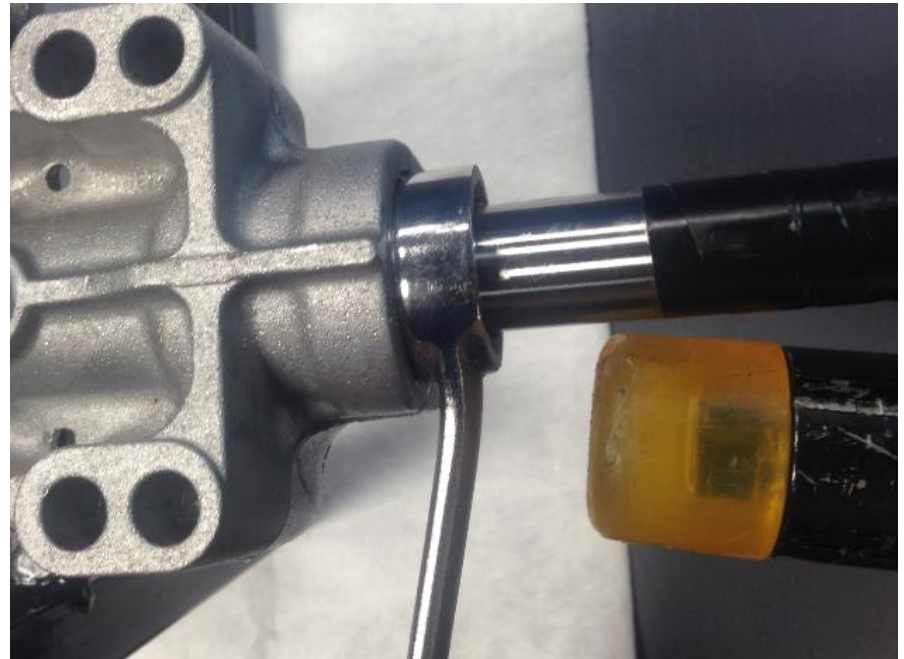

 Remove the fan and pulley stack up prior to oil inspection.

 Remove the snap ring, fan, and pulley. Please note the stack up of the pulley, fan, washer etc.

 Discard the old snap ring. Note the orientation of the original fan/pulley stack up for proper re-installation.

 Inspect the e-clip.

Note: Typically the e-clip can be reused, but if the clip appears worn then we suggest that it is replaced.



 The oil should be inspected before placing the transaxle back on the mower. Remove the sealing cap by prying up with a flat screw driver. Also remove the magnet prior to inspection or draining/refilling.



 See oil level height below. Oil level should be maintained at 20~25 mm (3/4"~1") below the lip of (black cap) port. Generally after a leak it is recommended to drain and refill the oil with approx. 2.3 liters of fresh 5W-50 Synthetic Oil. Once the oil level is correct be sure to reinstall the magnet and the sealing cap.

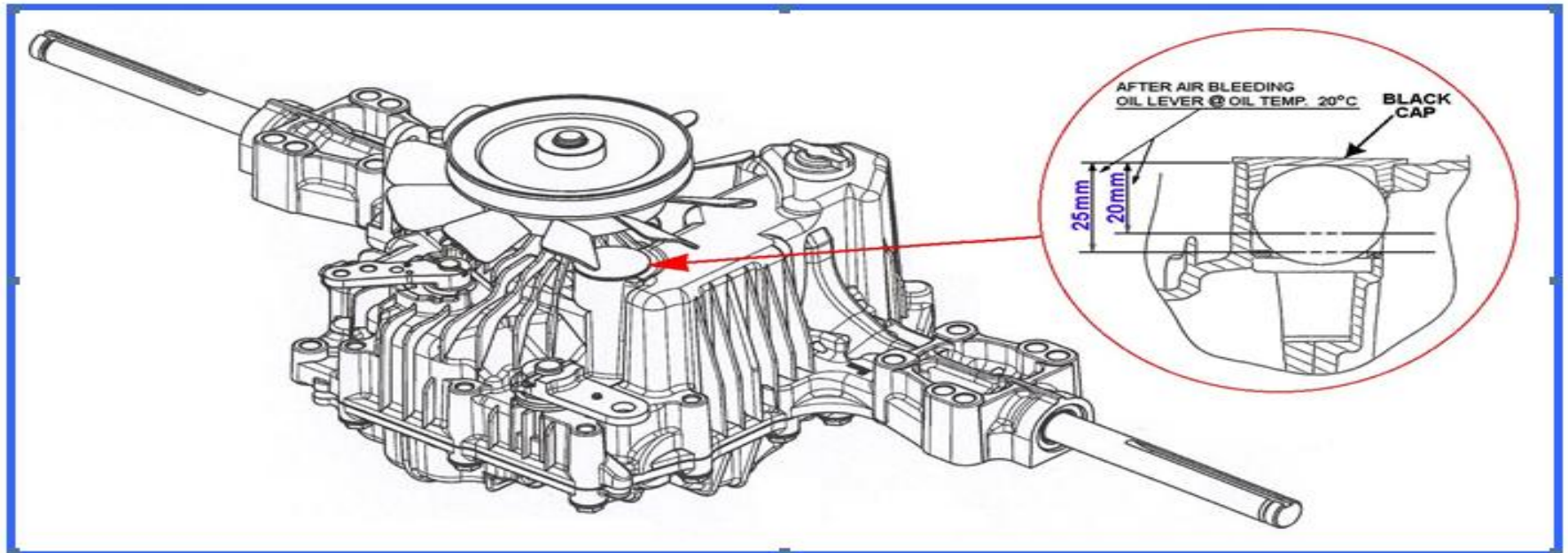

 Once the oil is properly filled re-install the fan/pulley assembly.

 Install the e-clip back on the shaft.

 Install the fan, washer, pulley and new snap ring. **Note:** Proper orientation is critical.

